

■ AC CLAMP-ON METER

# CM 610

# CM 625

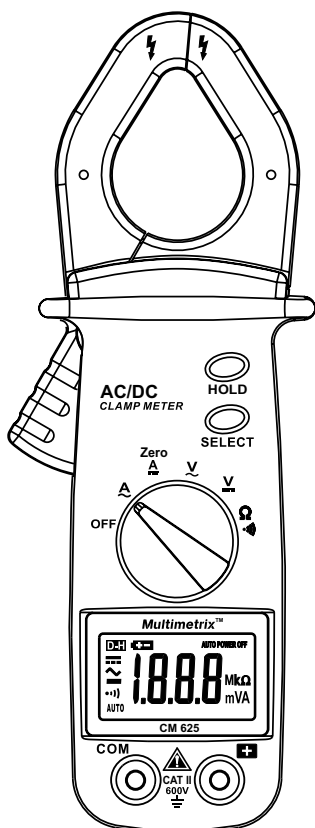
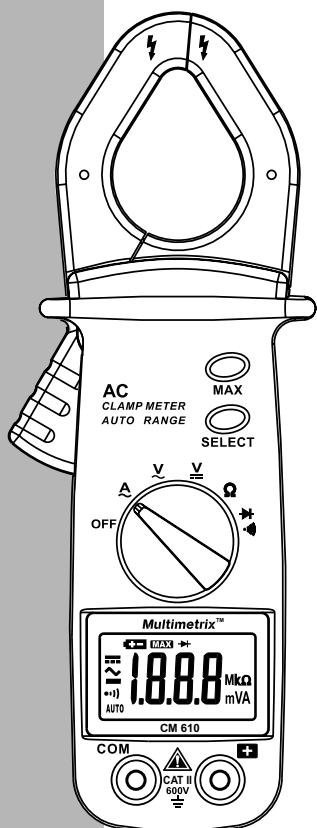

# Table of Contents

---

---

<b>1. INTRODUCTION .....</b>	<b>3</b>
Warning.....	3
1.1 International Electrical Symbols.....	3
1.2 Receiving Your Shipment.....	4
1.3 Ordering Information.....	4
<b>2. PRODUCT FEATURES .....</b>	<b>5</b>
2.1 Control Features.....	5
2.2 Display Features.....	6
2.3 Button Functions.....	7
2.3.1 Auto-off Function.....	7
2.3.2 HOLD Button - (CM 625 only).....	7
2.3.3 MAX Button - (CM 610 only).....	7
<b>3. SPECIFICATIONS .....</b>	<b>9</b>
3.1 Model CM 610 .....	9
3.1.1 Electrical Specifications .....	9
AC Amperes (TRMS) .....	9
AC Volts (TRMS).....	9
DC Volts .....	9
Resistance ( $\Omega$ ) .....	10
Continuity ( $\bullet\bullet$ ).....	10
Diode ( $\blacktriangleright$ ).....	10
3.2 Model CM 625 .....	11
3.2.1 Electrical Specifications .....	11
AC Amperes (TRMS) .....	11
AC Volts (TRMS).....	11
DC Amperes.....	11
DC Volts .....	11
Resistance ( $\Omega$ ) .....	12
Continuity ( $\bullet\bullet$ ).....	12
3.3 General Specifications.....	12
3.4 Environmental Specifications.....	13

3.5	Mechanical Specifications .....	13
3.6	Safety Specifications .....	13
<b>4.</b>	<b>OPERATION .....</b>	<b>14</b>
4.1	Preparation Before Use .....	14
4.2	AC Current Measurement.....	15
4.3	DC Current Measurement - (CM 625 only).....	16
4.4	AC Voltage Measurement.....	17
4.5	DC Voltage Measurement.....	18
4.6	Resistance Measurement.....	19
4.7	Continuity Test .....	20
4.8	Diode Test - (CM 610 only).....	21
<b>5.</b>	<b>MAINTENANCE .....</b>	<b>22</b>
5.1	Warning .....	22
5.2	Battery Replacement .....	22
5.3	Cleaning.....	22
	Repair and Calibration.....	23
	Limited Warranty .....	24
	Warranty Repairs.....	24

## INTRODUCTION

### **Warning**

These safety warnings are provided to ensure the safety of personnel and proper operation of the instrument.

- Read the instruction manual completely and follow all safety information before operating this instrument.
- Only use leads that comply with the IEC 61010. Before using them, always check that they are in perfect working order.
- Never exceed the protection limit values indicated in the specifications for each type of measurement.
- When the multimeter clamp is linked to the measurement circuits, do not touch any unused terminals.
- Before changing the function, disconnect the measurement leads from the circuit measured.
- Never measure resistances on a live circuit.

### 1.1 International Electrical Symbols



This symbol signifies that the instrument is protected by double or reinforced insulation. Use only specified replacement parts when servicing the instrument.



This symbol on the instrument indicates a WARNING and that the operator must refer to the user manual for instructions before operating the instrument. In this manual, the symbol preceding instructions indicates that if the instructions are not followed, bodily injury, installation/sample and product damage may result.



Risk of electric shock. The voltage at the parts marked with this symbol may be dangerous.

## 1.2 Receiving Your Shipment

Upon receiving your shipment, make sure that the contents are consistent with the packing list. Notify your distributor of any missing items. If the equipment appears to be damaged, file a claim immediately with the carrier and notify your distributor at once, giving a detailed description of any damage. Save the damaged packing container to substantiate your claim. Do not use an instrument that appears to be damaged.

## 1.3 Ordering Information

**Model CM 610**.....**Cat. #MMX-CM610**  
*Includes clamp-on meter CM 610, lead set (red & black lead) with needle point test probes, carrying case, 2x1.5V AAA batteries and a user manual.*

**Model CM 625**.....**Cat. #MMX-CM625**  
*Includes clamp-on meter CM 625, lead set (red & black lead) with needle point test probes, carrying case, 2x1.5V AAA batteries and a user manual.*

## PRODUCT FEATURES

### 2.1 Control Features

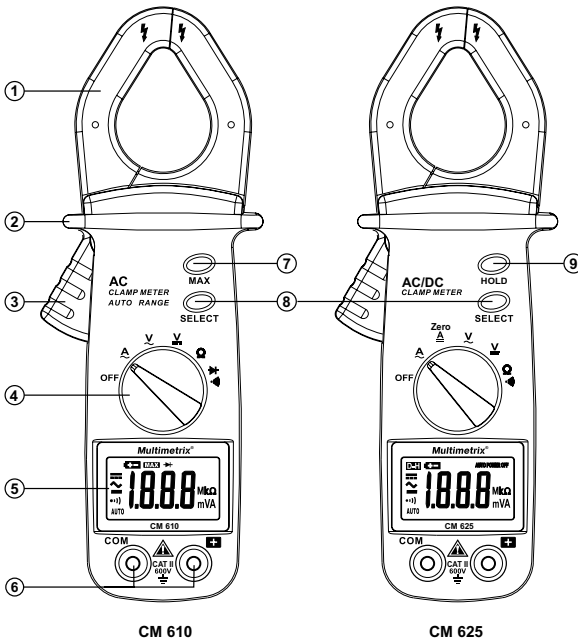

1. **Jaw assembly** - Jaws open to 1.18" (30 mm)
2. **Safety guard**
3. **Lever / Trigger** - Opens or closes jaws
4. **Rotary selection switch**
  - OFF** Zero voltage
  - A** AC current (CM 610: 600A and CM625: 400A)
  - Zero A** DC current (CM 625: 400A)
  - V** AC voltage (600A)
  - V** DC voltage (600V)
  - Ω** Resistance (CM 610: 20MΩ)
  - Ω ••** Resistance and continuity (CM 625: 40MΩ)
  - ▶ ••** Diode and continuity (CM 610)

5. **Display** - Liquid crystal display
6. **Positive and Negative terminals**  
 “COM” : Black  
 “+” : Red
7. **MAX button (CM 610)**  
 Displays the minimum and maximum values of a measurement
8. **SELECT button**  
 Selects diode or continuity test (CM 610)  
 Selects the measurement of the DC current or reset, or selects resistance or continuity test (CM 625)
9. **HOLD button (CM 625)** - Freezes last measured value on display

**NOTE:** See §2.3 for button functions

## 2.2 Display Features

Model CM 610

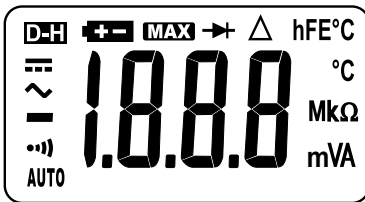

Model CM 625

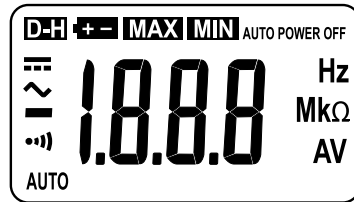

	DC mode
	AC mode
	Negative polarity
	Continuity
AUTO	Auto range
	Low battery
<b>MAX</b>	Maximum value
	Diode Test
MkΩ	Resistance
mVA	Current voltage
<b>D-H</b>	Data Hold
AUTO POWER OFF	Auto-off enabled

## 2.3 Button Functions

### 2.3.1 Auto-Off Function

Except in the **HOLD** or **MAX** function, the clamp-on meter shuts down automatically approximately 10 minutes after the last measurement. The buzzer sounds one minute before shutdown.

Pressing any button except **SELECT** restarts the clamp-on meter.

#### To disable the Auto-Off function - (CM 625 only):

- Turn the rotary switch to **OFF**
- Press and hold down the **HOLD** button and set the rotary switch to any position other than **OFF**
- The **AUTO POWER OFF** icon disappears and the automatic shutdown is deactivated

#### To enable the Auto-Off function - (CM 625 only):

- Turn the rotary switch to **OFF**
- Set the rotary switch to any position other than **OFF**
- The **AUTO POWER OFF** icon is displayed and the automatic shutdown is activated

### 2.3.2 HOLD Button - (CM 625 only)

This function locks the present displayed value.

When in this mode, the Auto-off function is automatically deactivated.

- Press the **HOLD** button during the measurement
- The **D-H** icon appears and the measurement is locked
- To deactivate, press the **HOLD** button again

### 2.3.3 MAX Button - (CM 610 only)

Set the selector to one of the following positions:  $\underline{V}$ ,  $\underline{V}$  or  $\underline{A}$ .

When in this mode, the Auto-Off function is automatically deactivated.

- To record maximum values, take the measurement and press the MAX button once.
- The **MAX** icon appears and recording maximum values has now been activated. MAX value  $V_p$  appears on the screen.
- **To exit the MAX mode**, hold the **MAX** button down for 2 seconds. The icon will disappear.

---

# CHAPTER 3

---

## SPECIFICATIONS

### 3.1 Model CM 610

#### 3.1.1 Electrical Specifications

##### AC Amperes (TRMS)

Range	Resolution	Accuracy	Frequency
200A	0.1A	1.9% ± 10cts	50 to 500Hz
600A	1A	1.9% ± 5cts	

##### AC Volts (TRMS)

Range	Resolution	Accuracy	Input Impedance
2V	1mV	1.5% ± 10cts	10MΩ
20V	10mV		11MΩ
200V	100mV	1.5% ± 5cts	10MΩ
600V	1V		

**Frequency:** 40 to 500Hz

**Overload Protection:** 660Vrms

##### DC Volts

Range	Resolution	Accuracy	Impedance
200mV	0.1mV	0.7% ± 3cts	100MΩ
2V	1mV	1.3% ± 3cts	10MΩ
20V	10mV		11MΩ
200V	100mV	1.0% ± 3cts	10MΩ
600V	1V		

**Overload Protection:** 660Vrms

## Resistance ( $\Omega$ )

Range	Resolution	Accuracy	Test Voltage
200 $\Omega$	0.1 $\Omega$	1.5% $\pm$ 5cts	Open Voltage: 0.4V
2000 $\Omega$	1 $\Omega$		
20k $\Omega$	0.01k $\Omega$		
200k $\Omega$	0.1k $\Omega$		
2M $\Omega$	0.001M $\Omega$	5.0% $\pm$ 5cts	
20M $\Omega$	0.01M $\Omega$	10.0% $\pm$ 5cts	

Protection: 600V

## Continuity ( $\bullet\text{---}\bullet$ )

Range	Buzzer	Resolution	Test Voltage
0 to 200 $\Omega$	<60 $\Omega$ $\pm$ 20 $\Omega$	0.1 $\Omega$	Open Voltage: 0.4V

Protection: 600V

## Diode ( $\blacktriangleright\text{---}\text{---}\blacktriangleleft$ )

Range	Resolution	Test Voltage
0 to 2V	0.001V	Open Voltage: 0.4V

Protection: 600V

*\*Accuracy given @ 23°C  $\pm$ 5°C, 80% RH Max, Conductor centered in jaws, 48-65Hz, No DC Component.*

## 3.2 Model CM 625

### 3.2.1 Electrical Specifications

#### AC Amperes (TRMS)

Range	Resolution	Accuracy	Frequency
40A	10mA	1.5% ± 10cts	50 to 500Hz
400A	100mA	1.5% ± 5cts	

#### AC Volts (TRMS)

Range	Resolution	Accuracy	Input Impedance
4V	1mV	1.0% ± 5cts	11MΩ <50pF
40V	10mV		10MΩ <50pF
400V	100mV		
600V	1V		

**Overload Protection:** 660Vrms

#### DC Amperes

Range	Resolution	Accuracy
40A	10mA	1.5% ± 10cts
400A	100mA	1.5% ± 5cts

#### DC Volts

Range	Resolution	Accuracy	Impedance
4V	1mV	0.75% ± 2cts	11MΩ
40V	10mV		10MΩ
400V	100mV		
600V	1V		

**Protection:** 660Vrms

## Resistance ( $\Omega$ )

Range	Resolution	Accuracy	Test Voltage
400 $\Omega$	0.1 $\Omega$	0.9% $\pm$ 2cts	< 3.4 to 0.7V
4000 $\Omega$	1 $\Omega$		
40k $\Omega$	0.01k $\Omega$		
400k $\Omega$	0.1k $\Omega$		
4M $\Omega$	0.001M $\Omega$	2.0% $\pm$ 2cts	
40M $\Omega$	0.01M $\Omega$	5.0% $\pm$ 2cts	

Protection: 600V

## Continuity (•••)

Range	Buzzer	Resolution	Test Voltage
0 to 400 $\Omega$	<50 $\Omega$ $\pm$ 25 $\Omega$	0.1 $\Omega$	< 3.4V

Protection: 600V

*\*Accuracy given @ 23°C  $\pm$ 5°C, 80% RH Max, Conductor centered in jaws, 45-65Hz, No DC Component.*

## 3.3 General Specifications

### Digital display:

3 $\frac{3}{4}$  digit LCD

2000-count - CM 610; 4300-count - CM 625

### Polarity:

When a negative signal is applied, the  symbol appears.

### Overload:

If the range is exceeded, the  symbol is displayed.

### Low battery indicator:

 is displayed when the voltage supplied by the batteries is lower than the operating voltage.

### Power Supply:

2 batteries - 1.5V type AAA (LR03)

### Battery life:

240hrs approx

### Auto-Off (CM 625 only):

Automatic shut down after approx 10 min of no use

### **3.4 Environmental Specifications**

**Operating Temperature:**

32° to 122°F (0° to 50°C), 80% RH max non-condensing

**Storage Temperature:**

14° to 140°F (-10° to 60°C), 70% RH max non-condensing

**Altitude:**

6000 ft (2000m)

### **3.5 Mechanical Specifications**

**Maximum jaw opening:** Ø 1.18" (30mm)

**Dimensions:** 7.44 x 2.80 x 1.46" (189 x 71 x 37mm)

**Weight:** 8.0 oz (220 g)

### **3.6 Safety Specifications**

IEC/EN 61010-1 and 2-032 - 600V Cat. II and 300V Cat. III

Pollution Degree 2; Class 2



## OPERATION

### 4.1 Preparation Before Use



For your own safety and to prevent damage to the instrument, you must follow the instructions given in this manual.

#### **This instrument can be used for measurements:**

- on circuits in installation category II, in an environment with pollution level 2, for voltages no greater than 600V in relation to the earth.
- or on circuits in installation category III, in an environment with pollution degree level 2, for voltages no greater than 300V in relation to the earth.

Definition of the installation categories (see IEC/EN 61010-1 publication):

CAT II: CAT II circuits are household or similar appliance power circuits, which may carry medium-level transient over-voltage.

Example: household appliance and portable tool power supplies

CAT III: CAT III circuits are high-power appliance power circuits, which may carry high-level transient over-voltage.

Example: industrial machinery or instrument power supplies

For your own safety, only use leads that comply with the IEC/EN 61010. Before using them, always check that they are in perfect working order.

## 4.2 AC Current Measurement

Automatic measurement ranges: 200AAC or 600AAC (CM 610)  
40AAC or 400AAC (CM 625)

- Turn the rotary switch to the **A** range
- Remove the test leads before measuring current
- Clamp the jaws around the conductor to be measured
- Take the current reading after it stabilizes



**Warning:** “-----” indicates that the capacity has been exceeded.

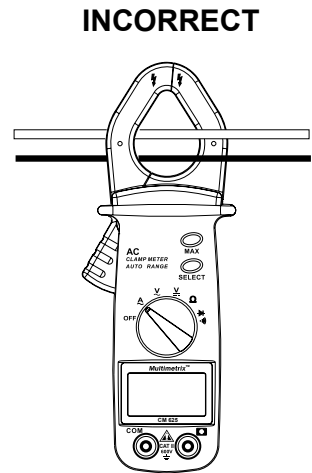
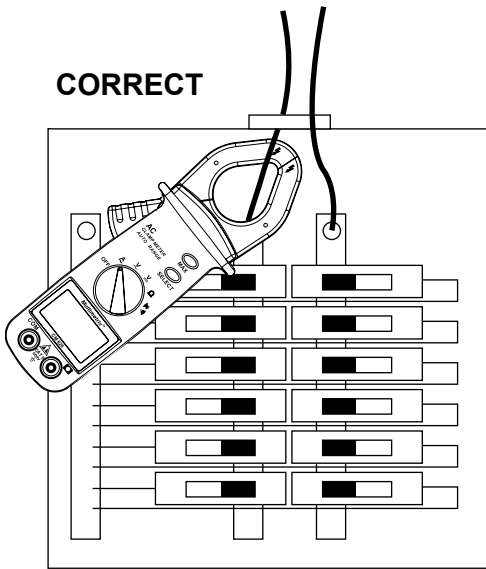

### 4.3 DC Current Measurement - (CM 625 only)

Automatic measurement ranges: 40ADC or 1000ADC

- Turn the rotary switch to the **Zero A** range
- Press the **SELECT** button to reset (zero) the probe (reset is only available on the 40A range)
- Remove the test leads before measuring current
- Clamp the jaws around the conductor to be measured
- Take the current reading after it stabilizes



**Warning:** “-----” indicates that the capacity has been exceeded. The  icon indicates reversal of the contact point's polarity.

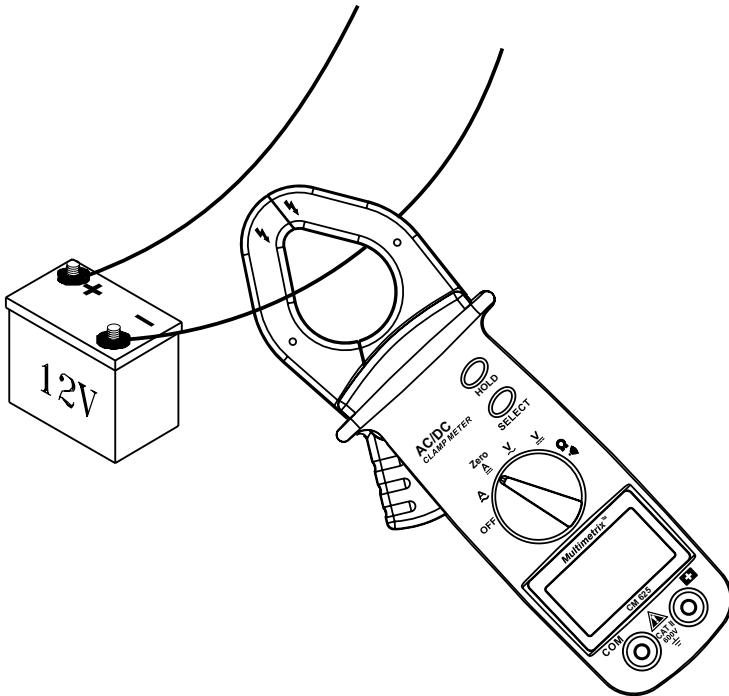

## 4.4 AC Voltage Measurement

Automatic measurement ranges: 2VAC or 600VAC (CM 610)  
4VAC to 600VAC (CM625)

- Turn the rotary switch to the  $\surd$  range.
- Insert the red lead to the red "+" input jack and the black lead to the black "COM" input jack.
- Bring the test probe tips into contact with the test points.
- Take the voltage reading after it stabilizes.



**Warning:** "-----" indicates that the capacity has been exceeded.

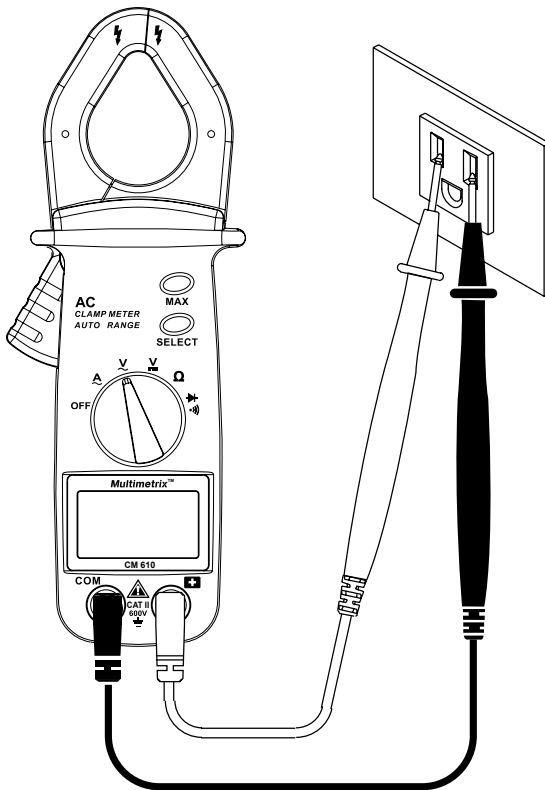

## 4.5 DC Voltage Measurement

Automatic measurement ranges: 200mVDC or 600VDC (CM 610)  
4VDC to 600VDC (CM 625)

- Turn the rotary switch to the  $\underline{V}$  range.
- Insert the red lead to the red “+” input jack and the black lead to the black “COM” input jack.
- Take the voltage reading after it stabilizes.



**Warning:** “-----” indicates that the capacity has been exceeded.  
The  icon indicates reversal of the contact point’s polarity.

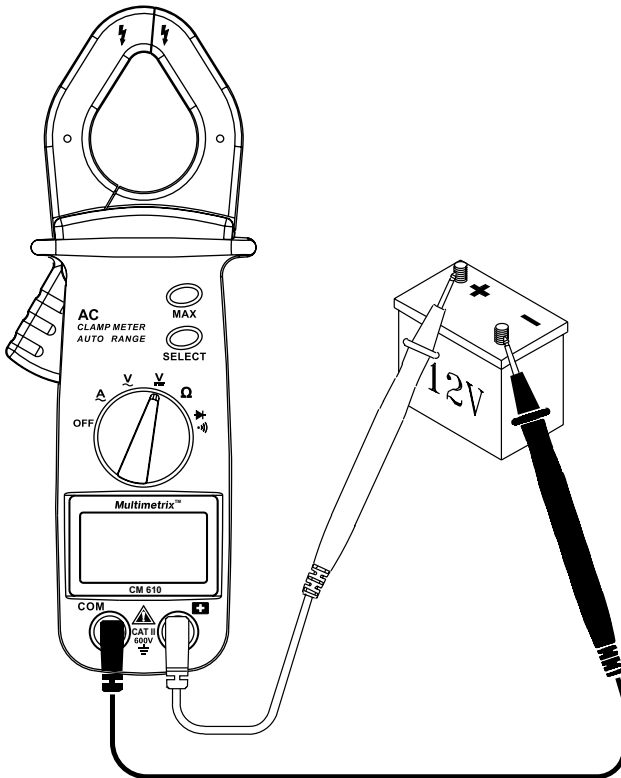

## 4.6 Resistance Measurement

Automatic measurement ranges: 200 $\Omega$  or 20M $\Omega$  (CM 610)  
400 $\Omega$  or 40M $\Omega$  (CM 625)



**Note:** When making a resistance measurement, make sure that the power is off (dead circuit). It is also important that all capacitors in the measured circuit be fully discharged.

- Turn the rotary switch to the  $\Omega$  range (CM 610) or Turn the rotary switch to the  $\Omega \cdot \bullet \bullet$  range (CM 625).
- Insert the red lead to the red "+" input jack and the black lead to the black "COM" input jack.
- Bring the test probe tips into contact with the sample under test.



**Warning:** If overload "OL" is displayed, the resistance exceeds the measurement range or the circuit is open.

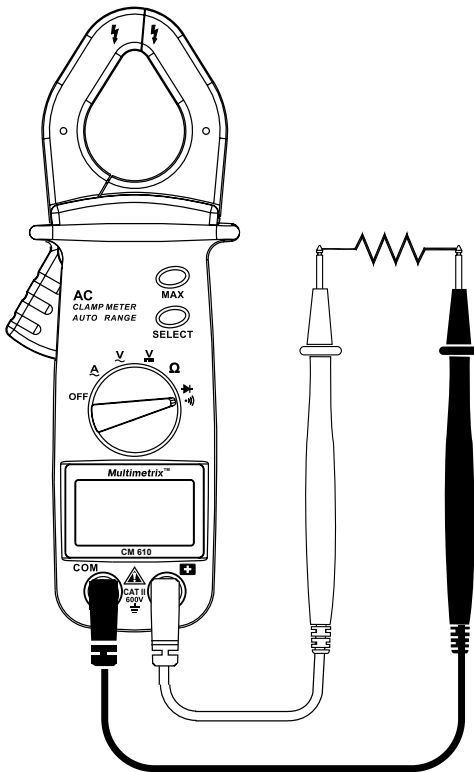

## 4.7 Continuity Test



**Note:** When testing continuity, make sure that the power is off (dead circuit).

- Turn the rotary switch to the  $\rightarrow \text{••})$  range (CM 610) or Turn the rotary switch to the  $\Omega \text{••})$  range (CM 625).
- Press the **SELECT** button to select continuity ( $\text{••})$  will appear on the display).
- Insert the red lead to the red "+" input jack and the black lead to the black "COM" input jack.
- Bring the test probe tips into contact with the sample under test.
- If the resistance is less than  $60\Omega \pm 20\Omega$  (CM 610) or  $50\Omega \pm 25\Omega$  (CM 625), the beeper emits a continuous sound.



**Warning:** If overload "OL" is displayed, the continuity exceeds the measurement range or the circuit is open.

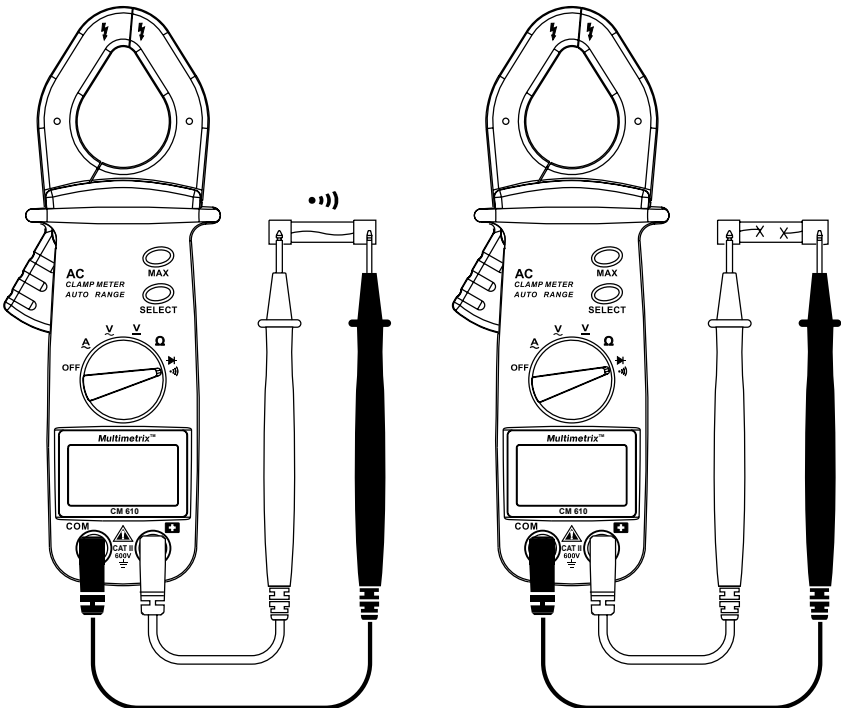

## 4.8 Diode Test - (CM 610 only)



**Note:** When testing continuity, make sure that the power is off (dead circuit).

- Turn the rotary switch to the  $\rightarrow \bullet \bullet \bullet$  range.
- Insert the red lead to the red "+" input jack and the black lead to the black "COM" input jack.
- Bring the test probe tips into contact with the sample under test
- Proceed to test directly.  
Connect the black contact to the cathode and the red contact to the anode. The measurement is 0.5 to 0.7V for a silicon diode and 0.2 to 0.3V for a germanium diode. A value close to zero indicates a short-circuit. OL indicates a diode has shorted out.
- Proceed to test in reverse.  
Connect the black contact to the anode and the red contact to the cathode. A correct diode will show OL. The diode is defective if a voltage is displayed.

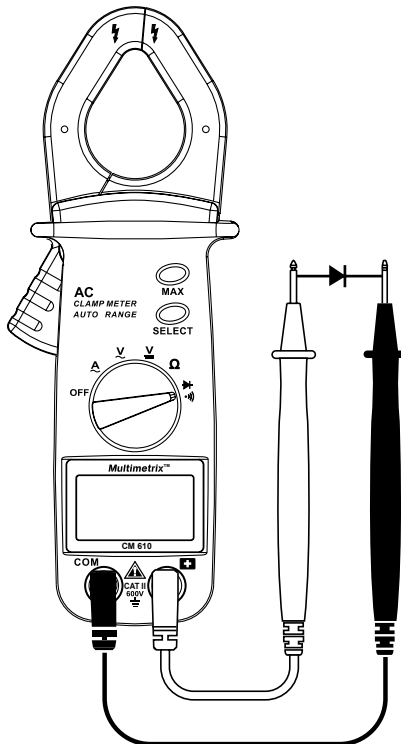

## MAINTENANCE

### 5.1 Warning

- Remove the test leads from any input before opening the case. Do not operate the instrument without a battery case cover.
- To avoid electrical shock, do not attempt to perform any servicing unless you are qualified to do so.
- If the meter is not going to be used for a long period of time, take out the batteries. Do not store the meter in high temperatures or high humidity.
- To avoid electrical shock and/or damage to the instrument, do not get water or other foreign agents into the probe.

### 5.2 Battery Replacement

- The batteries will need to be replaced when the **+ -** symbol appears on the display.
- The meter must be in the OFF position and disconnected from any circuit or input.
- Remove the battery cover screws with a screwdriver.
- Replace the old batteries with two new 1.5V AAA (LR03) batteries.
- Replace the battery compartment cover and tighten the screws.

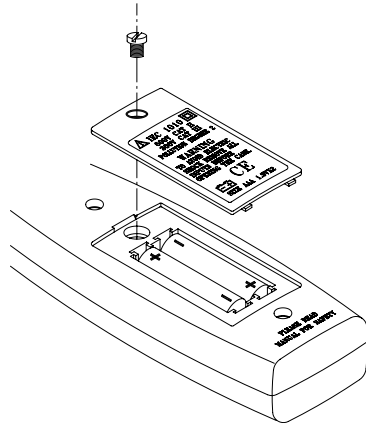

### 5.3 Cleaning

- To clean the instrument, wipe the case with a damp cloth and mild detergent. Do not use abrasives or solvents.
- Do not get water inside the case. This may lead to electrical shock or damage to the instrument.

---

## Repair and Calibration

---

To ensure that your instrument meets factory specifications, we recommend that it be scheduled back to our factory Service Center at one-year intervals for recalibration, or as required by other standards or internal procedures.

### For instrument repair and calibration:

You must contact our Service Center for a Customer Service Authorization Number (CSA#). This will ensure that when your instrument arrives, it will be tracked and processed promptly. Please write the CSA# on the outside of the shipping container. If the instrument is returned for calibration, we need to know if you want a standard calibration, or a calibration traceable to N.I.S.T. (Includes calibration certificate plus recorded calibration data).

**Ship To:** Multimetrix®  
15 Faraday Drive  
Dover, NH 03820 USA  
Tel: (800) 945-2362 (Ext. 360)  
(603) 749-6434 (Ext. 360)  
Fax: (603) 742-2346 or (603) 749-6309  
repair@multimetrix.com

(Or contact your authorized distributor)

Costs for repair, standard calibration, and calibration traceable to N.I.S.T. are available.

**NOTE: You must obtain a CSA# before returning any instrument.**

---

## Technical and Sales Assistance

---

If you are experiencing any technical problems, or require any assistance with the proper operation or application of your instrument, please call, mail, fax or e-mail our technical support team:

Multimetrix®  
200 Foxborough Boulevard  
Foxborough, MA 02035 USA  
Phone: (800) 343-1391  
(508) 698-2115  
Fax: (508) 698-2118  
techsupport@multimetrix.com  
www.multimetrix.us

**NOTE: Do not ship Instruments to our Foxborough, MA address.**

---

## Limited Warranty

---

The Model CM 610 and CM 625 are warranted to the owner for a period of one year from the date of original purchase against defects in manufacture. This limited warranty is given by Multimetrix™, not by the distributor from whom it was purchased. This warranty is void if the unit has been tampered with, abused or if the defect is related to service not performed by Multimetrix™.

**For full and detailed warranty coverage, go to [www.multimetrix.us](http://www.multimetrix.us). The warranty information is located in our customer service section.**

### **What Multimetrix™ will do:**

If a malfunction occurs within the one-year period, you may return the instrument to us for repair, provided you submit a proof of purchase. Multimetrix™ will, at its option, repair or replace the faulty material.

---

## Warranty Repairs

---

### **What you must do to return an Instrument for Warranty Repair:**

First, request a Customer Service Authorization Number (CSA#) by phone or by fax from our Service Department (see address below), then return the instrument along with the signed CSA Form. Please write the CSA# on the outside of the shipping container. Return the instrument, postage or shipment pre-paid to:

Multimetrix™  
Service Department  
15 Faraday Drive • Dover, NH 03820 USA  
Tel: (800) 945-2362 (Ext. 360)  
(603) 749-6434 (Ext. 360)  
Fax: (603) 742-2346 or (603) 749-6309

**Caution:** To protect yourself against in-transit loss, we recommend you insure your returned material.

**NOTE:** You must obtain a CSA# before returning any instrument.

# **Multimetrix®**

07/04

99-MAN 100002 v1

**Multimetrix®** a division of Chauvin Arnoux®, Inc.  
15 Faraday Drive • Dover, NH 03820 USA  
[www.multimetrix.us](http://www.multimetrix.us)