

AC Current Probe Model JM852

User Manual

DESCRIPTION

The JM852 (Catalog #2113.41) is designed for use in industrial environments. The "squared" jaws permit multiple conductor or bus bar positioning. The voltage output makes it the perfect tool for measurement with DMMs, recorders, power and harmonic meters. The Model JM852 is compatible with any voltmeter, multimeter, or other voltage measuring instrument with an input impedance greater than 100K Ω . To achieve the stated accuracy, use the JM852 with the DMM having an accuracy of 0.75%.

WARNING

These safety warnings are provided to ensure the safety of personnel and proper operation of the instrument.

- Read the instruction manual completely and follow all the safety information before attempting to use or service this instrument.
- Use caution on any circuit: Potentially high voltages and currents may be present and may pose a shock hazard.
- Read the Safety Specifications section prior to using the current probe. Never exceed the maximum voltage ratings given.
- Safety is the responsibility of the operator.
- ALWAYS connect the current probe to the display device before clamping the probe onto the sample being tested.
- ALWAYS inspect the instrument, probe, probe cable, and output terminals prior to use. Replace any defective parts immediately.
- NEVER use the current probe on electrical conductors rated above 600V in overvoltage category III (CAT III). Use extreme caution when clamping around bare conductors or bus bars.

INTERNATIONAL ELECTRICAL SYMBOLS



This symbol signifies that the current probe is protected by double or reinforced insulation. Use only factory specified replacement parts when servicing the instrument.



This symbol signifies CAUTION! and requests that the user refer to the user manual before using the instrument.



This is a type A current sensor. This symbol signifies that application around and removal from HAZARDOUS LIVE conductors is permitted.

DEFINITION OF MEASUREMENT CATEGORIES

- Cat. I:** For measurements on circuits not directly connected to the AC supply wall outlet such as protected secondaries, signal level, and limited energy circuits.
- Cat. II:** For measurements performed on circuits directly connected to the electrical distribution system. Examples are measurements on household appliances or portable tools.
- Cat. III:** For measurements performed in the building installation at the distribution level such as on hardwired equipment in fixed installation and circuit breakers.
- Cat. IV:** For measurements performed at the primary electrical supply (<1000V) such as on primary overcurrent protection devices, ripple control units, or meters.

RECEIVING YOUR SHIPMENT

Upon receiving your shipment, make sure that the contents are consistent with the packing list. Notify your distributor of any missing items. If the equipment appears to be damaged, file a claim immediately with the carrier and notify your distributor at once, giving a detailed description of any damage.

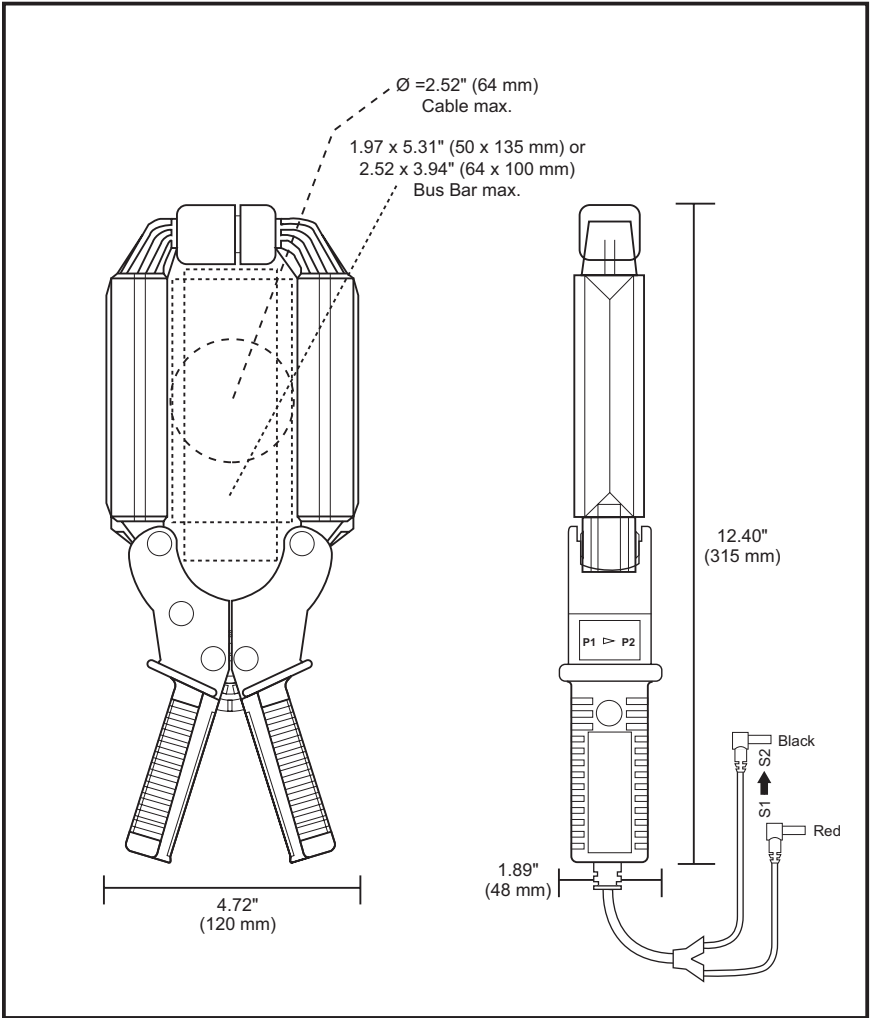

ELECTRICAL SPECIFICATIONS

Current Range:

1 to 2400A AC, continuous cycle for the full temperature range (3000A if temperature < 35°C or 95°F)

Transformation Ratio:

3000:1

Output Signal:

0.333 mV AC/A AC (1V at 3000A)

Accuracy and Phase Shift*:

Primary current	150A	600A	3000A
Accuracy %	1.5%	0.75%	0.5%
Phase shift	1.5°	0.75°	0.5°

(*Reference conditions: 23°C±3°K, 20 to 85% RH, 48 to 65 Hz, external magnetic field < 40 A/m, no DC component, no external current carrying conductor, test sample centered.) Load impedance 1 MΩ.

Overload: 3600A during 5 mn

Accuracy: Per IEC 185-26-27
Class 0.5 from 48 to 1000 Hz

Frequency Range:
30 Hz to 5 kHz; current derating above
1 kHz for continuous use

Ampere Second Product: 90 AA

Load Impedance: $\geq 100 \text{ K}\Omega$

Working Voltage: 600V AC

Common Mode Voltage: 600V AC

Influence of Adjacent Conductor:
0.005A/A AC

Influence of Conductor in Jaw Opening:
1% \pm 0.1A of reading

MECHANICAL SPECIFICATIONS

Operating Temperature:
14° to 122°F (-10° to 50°C)

Storage Temperature:
-13° to 176°F (-25° to 80°C)

Influence of Temperature:
< 0.2% per 10°K

Jaw Opening: 3.54" (90 mm)

Maximum Conductor Size:
Cable: 2.52" \varnothing max. (64mm)
Bus bar: 1.97 x 5.31" (50 x 135 mm)
2.52 x 3.94" (64 x 100 mm)

Envelope Protection:
IP 20 (IEC 529)

Drop Test:
500 mm (IEC 68-2-32)

Mechanical Shock:
100 g (IEC 68-2-27)

Vibration:
10/55/10 Hz, 0.15 mm (IEC 68-2-6)

Polycarbonate Material:
Handles: 10% fiberglass charged
polycarbonate UL 94 V0
Jaws: ABS UL 94 V2

Dimensions:
4.72 x 12.40 x 1.89" (120 x 315 x 48 mm)

Weight:
2.65 lbs. (1200 g)

Colors:
Dark gray handles with red jaws

Output:
5 ft (1.5m) lead with safety 4mm banana plug

SAFETY SPECIFICATIONS



Electrical:
Double insulation or reinforced insulation
between primary or secondary and outer case of
handle upon IEC 1010-2-32

Common Mode Voltage:
600V Category III, Pollution: 2

ORDERING INFORMATION

Current Probe JM852 **Cat #2113.41**
*Includes a user manual and a product warranty
and registration card*

Accessories:
Banana plug adapter
(to nonrecessed plug)..... **Cat #1017.45**

OPERATION

Please make sure that you have already read and fully understand the WARNING section on page 1.

Making Measurements with the AC Current Probe Model JM852

- Connect the black and red terminals to the Voltage AC range of your DMM or voltage measuring instrument. Select the appropriate voltage range (2V AC). Clamp the probe around the conductor to be tested. If the reading is less than 200 mV, select the lower range until you obtain the best resolution. Read the value display on the DMM and multiply it by the probe ratio (3000/1 = 3000). (If reading = 0.592V AC, the current flowing through the probe is $0.592 \times 3000 = 1776A$).
- For best accuracy: carefully center the conductor inside the probe jaw, avoid if possible, the proximity of other conductors which may create noise.

Tips for Making Precise Measurements

- When using a current probe with a meter, it is important to select the range that provides the best resolution. Failure to do this may result in measurement errors.
- Make sure that probe jaw mating surfaces are free of dust and contamination. Contaminants cause air gaps between the jaws, increasing the phase shift between primary and secondary. It is very critical for power measurement.

MAINTENANCE:



- For maintenance use only original replacement parts.
- To avoid electrical shock, do not attempt to perform any servicing unless you are qualified to do so.
- To avoid electrical shock and/or damage to the instrument, do not get water or other foreign agents into the probe.

Cleaning

To ensure optimum performance, it is important to keep the probe jaw mating surfaces clean at all times. Failure to do so may result in error in readings. To clean the probe jaws, use a very fine sand paper (fine 600) to avoid scratching the jaw, then gently clean with a soft oiled cloth.

REPAIR AND CALIBRATION

You must contact our Service Center for a Customer Service Authorization number (CSA#). This will ensure that when your instrument arrives, it will be tracked and processed promptly. Please write the CSA# on the outside of the shipping container. If the instrument is returned for calibration, we need to know if you want a standard calibration, or a calibration traceable to N.I.S.T. (includes calibration certificate plus recorded calibration data).

Chauvin Arnoux[®], Inc. d.b.a. AEMC[®] Instruments
15 Faraday Drive • Dover, NH 03820 USA
Tel: (800) 945-2362 (Ext. 360)
(603) 749-6434 (Ext. 360)
Fax: (603) 742-2346 or (603) 749-6309
repair@aemc.com

(Or contact your authorized distributor)

Costs for repair, standard calibration, and calibration traceable to N.I.S.T. are available.

NOTE: All customers must obtain a CSA# before returning any instrument.

TECHNICAL AND SALES ASSISTANCE

If you are experiencing any technical problems, or require any assistance with the proper use or application of this instrument, please call our technical hotline:

(800) 343-1391 • (508) 698-2115 • Fax (508) 698-2118
Chauvin Arnoux[®], Inc. d.b.a. AEMC[®] Instruments
techsupport@aemc.com
www.aemc.com