

Hipot Electrical Safety Tester Models H110/H115/H210/H215

USER MANUAL

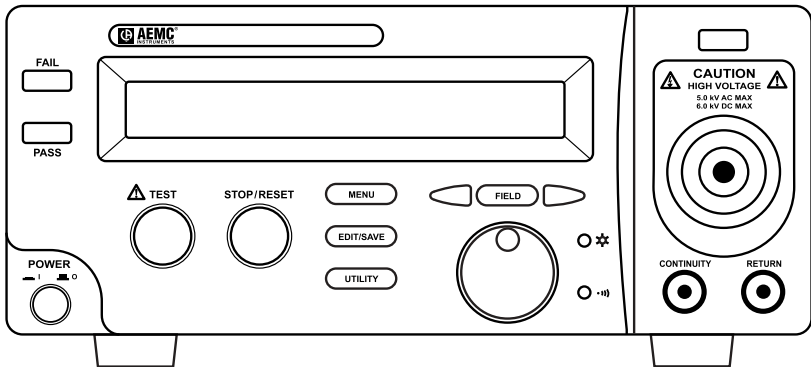

WARNING

- THIS INSTRUMENT GENERATES AND OUTPUTS A POTENTIALLY DANGEROUS HIGH VOLTAGE (5kV/6kV).
- BE EXTREMELY CAREFUL WHEN USING THIS INSTRUMENT.
- BE SURE TO READ THE SAFETY PRECAUTIONS IN SECTION 3 BEFORE OPERATING.

Limited Warranty

The Hipot Safety Testers are warranted to the owner for a period of 1 year from the date of original purchase against defects in manufacture. This limited warranty is given by AEMC® Instruments, not by the distributor from whom it was purchased. This warranty is void if the unit has been tampered with, abused or if the defect is related to service not performed by AEMC® Instruments.

For full and detailed warranty coverage, please read the Warranty Coverage Card, which is attached to the Warranty Registration Card. Please keep the Warranty Coverage Card with your records.

What AEMC® Instruments Will Do:

If a malfunction occurs within the 1-year period, you may return the instrument to us for repair or replacement free of charge, provided we have your REGISTRATION CARD on file. AEMC® Instruments will, at its option, repair or replace the faulty material.

If a registration card is not on file, we will require a dated proof of purchase, as well as your REGISTRATION CARD accompanied by the defective material.

REGISTER ON LINE

www.aemc.com

Warranty Repairs

What you must do to return an Instrument for Warranty Repair:

First, request a Customer Service Authorization number (CSA#) by phone or by fax from our Service Department (see address below), then return the instrument along with the signed CSA Form. Please write the CSA number on the outside of the shipping container. Return the instrument, postage or shipment pre-paid to:

Chauvin Arnoux®, Inc. d.b.a. AEMC® Instruments
Service Department
15 Faraday Drive • Dover, NH 03820 USA
Tel: (800) 945-2362 (Ext. 360)
(603) 749-6434 (Ext. 360)
Fax: (603) 742-2346 or (603) 749-6309

Caution: To protect yourself against in-transit loss, we recommend you insure your returned material.

Note: All customers must obtain a CSA# before returning any instrument.



Note: Be sure to keep the original packaging (the box and the inserts) of your Hipot Tester purchase. You will need it to return the instrument for its yearly calibration.

Table of Contents

Warning	3
International Electrical Symbols	3
1. PRODUCT INTRODUCTION	5
1-1. Description	5
1-2. How to Order.....	5
1-3. Front and Rear Panel Features	6
1-4. Operational Features	9
2. SPECIFICATIONS.....	10
3. SAFETY PRECAUTIONS BEFORE OPERATION	12
3-1. Receiving your Shipment.....	12
3-2. Contents.....	12
3-3. Safety Notice.....	12
3-4. Environment.....	13
4. OPERATION METHOD.....	14
4-1. Main Display	14
4-2. Table of Parameters	14
4-3. Preparing the Hipot Tester for Use	16
Viewing the Saved Steps:.....	16
Edit/Save the Saved Steps:.....	17
Starting a Test:	19
Viewing Utility Functions:.....	21
Edit/Save Utility Functions:.....	23
4-4. Structure of Stored Tests : Steps	24
4-5. Menu Parameter Setup.....	25
AC/DC Withstanding Voltage Test (VAC/VDC):.....	25
Continuous AC/DC Withstanding Voltage Test	26
Insulation Resistance Test (IR)	27
Continuity Check (CNT).....	28
Functions of the Remote Interface:	29
5. MAINTENANCE	31
5-1. Fuse Rating and Type	31
5-2. Cleaning.....	31
Repair and Calibration.....	32
Technical and Sales Assistance.....	32



Warning



- **THIS INSTRUMENT GENERATES AND DELIVERS A POTENTIALLY DANGEROUS HIGH VOLTAGE (5kV).**
- **BE EXTREMELY CAREFUL WHEN USING THIS INSTRUMENT.**
- **BE SURE TO READ THE PRECAUTIONS IN SECTION 3 BEFORE OPERATING.**

These safety warnings are provided to ensure the safety of personnel and proper operation of the instrument.

- Read the instruction manual completely and follow all safety information before attempting to use or service this instrument.
- This instrument ***MUST*** be grounded before use.
- Only qualified personnel should use these testers.

International Electrical Symbols



This symbol signifies CAUTION! and requests that the user refer to the user manual before using the instrument.



High voltage; risk of electric shock. The voltage at the parts marked with this symbol may be dangerous.



Protective Conductor Terminal



Ground (Earth) Terminal

FOR THE UNITED KINGDOM ONLY:

The wires in this lead are colored in accordance with the following code:

Green/Yellow:	Earth (Ground)
Blue:	Neutral
Brown:	Live (Phase)

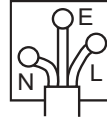

As the colors of the wires in the power cord may not correspond with the color markings identified in your plug/appliance, proceed as follows:

The Green & Yellow wire must be connected to the Earth terminal marked with the letter E or by the earth symbol  or colored Green or Green & Yellow.

The Blue wire must be connected to the terminal which is marked with the letter N or colored Blue or Black.

The Brown wire must be connected to the terminal marked with the letter L or P or colored Brown or Red.

If in doubt, consult the instructions provided with the equipment or contact the supplier.

A suitably rated and approved HBC power line fuse should protect this cable/appliance: refer to the rating information on the equipment and/or user instructions for details. As a guide, cable of 0.75mm^2 should be protected by a 3A or 5A fuse. Larger conductors would normally require 13A types, depending on the connection method used.

- Use caution on any apparatus: potentially high voltages and currents may be present and pose a shock hazard.
- Safety is the responsibility of the user.
- Always inspect the instrument and test cables prior to use. Replace defective parts immediately with factory replacement parts only.

1. PRODUCT INTRODUCTION

1-1. Description

The AEMC® Hipot Testers are designed for AC/DC Withstanding Voltage Testing and Insulation Resistance Testing (IR), providing a safe and accurate test environment for the operator. See section 1-4 for features to ensure a safe operation of high voltage testing and to protect the user from hazardous shock.

AEMC® Electrical Safety Testers comply with the requirement of the electrical equipment & appliance testing standard, UL, CSA, and other international standards. The testers can be used for withstanding voltage tests of the various types of electrical and equipment and components.

The testers include AC withstanding voltage test, DC withstanding voltage test and insulation resistance test.

Model	AC (5kV)	DC (6kV)	IR
H110	✓		
H115	✓		✓
H210	✓	✓	
H215	✓	✓	✓

1-2. How to Order

AC Hipot Tester, Model H110 #2117.81

AC Hipot / IR Tester, Model H115 #2117.82

AC/DC Hipot Tester, Model H210..... #2117.83

AC/DC Hipot / IR Tester, Model H215 #2117.84

All models include the tester, lead set with test probe, US power cord, 1 fuse (2A, 250V), and user manual.

Accessories:

HV Test Pistol, Model SP02..... #2117.88

HV Test Lead (3m) 9ft. unterminated at one end #2117.89

Fuse (set of 5) 4A, 250V #2117.90

Fuse (set of 5) 2A, 250V #2117.92

1-3. Front and Rear Panel Features

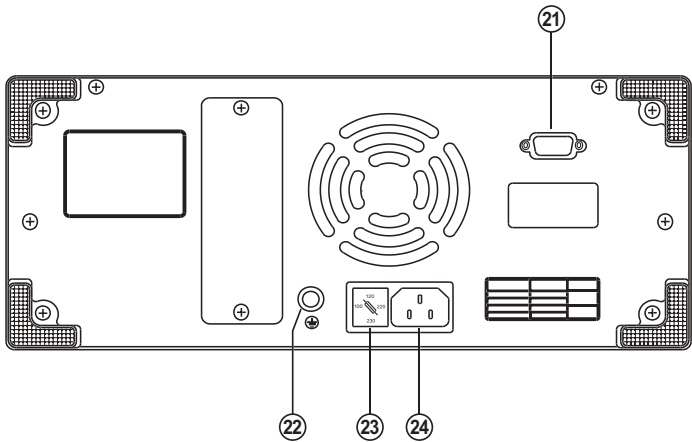
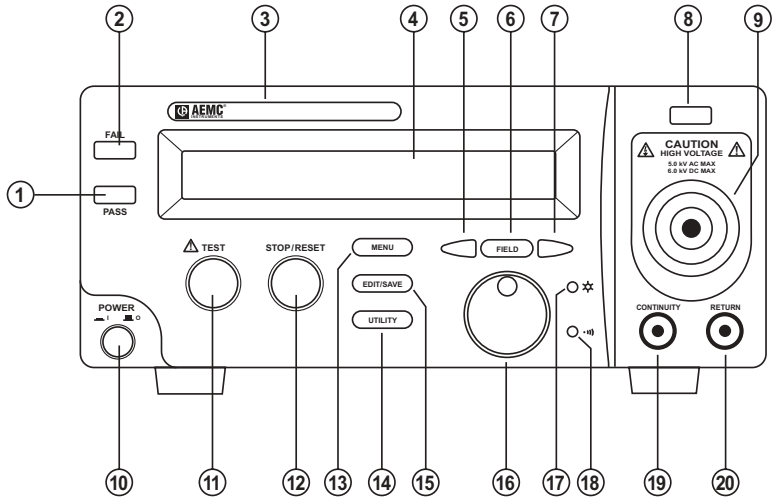

- 1) PASS Indicator LED - The Green LED indicates test passage.
- 2) FAIL Indicator LED - The Red LED indicates test failure.
- 3) Model number and description.
- 4) Main Display LCD - The LCD displays all messages, setup conditions and test results.
- 5) Left Arrow Key - Press the arrow key to select the setting. Adjustment is then made with the rotary knob.
- 6) FIELD Key - When in the "EDIT" mode, the FIELD key will scroll through the function parameters.
- 7) Right Arrow Key - Press the arrow key to select the setting. The adjustment is then made with the rotary knob.
- 8) CAUTION Indicator LED - During testing the Red LED above the high voltage output will flash to indicate that dangerous voltage is present.
- 9) High Voltage Output Plug - High voltage output terminal.
- 10) Power Switch - Press to turn the tester on and off.
- 11) TEST Button - Press the green button to start a test procedure.
- 12) STOP/RESET Button - Press the red button to reset/stop a test procedure.
- 13) MENU Key - When you press the MENU key, the "MENU" mode becomes active and you can select setup functions.
- 14) UTILITY Key - When you press the UTILITY key, the "UTILITY" mode is active and you can view all the utility setups.
- 15) EDIT/SAVE Key - When you press the EDIT/SAVE key, the "EDIT" mode is active and you can edit the current step or setup. Press the EDIT/SAVE key again will save this step or setup.

- 16) Rotary Knob - If the "EDIT" mode is active, turn the knob to increase or decrease the value of the active parameter. If the "MENU" mode is active, turn the knob to increase or decrease the active Step.
- 17) LCD Backlight Adjustment - Screwdriver adjustment for the LED backlight (use a small, insulated screwdriver).
- 18) Buzzer Volume Adjustment - Screwdriver adjustment for the buzzer volume (use a small, insulated screwdriver).
- 19) CONTINUITY Terminal - Continuity check output terminal.
- 20) RETURN Terminal - Test return terminal.
- 21) Remote Interface - The remote interface facilitates all of the functions via PLC control.
- 22) Ground Terminal - Connect Ground terminal to the earth ground.
- 23) Fuse Holder with Voltage Selector - To change AC source voltage, pull the fuse holder and rotate it to the proper value. (select fuse accordingly).
- 24) AC Plug - Accepts standard AC power line cords.

2. SPECIFICATIONS (15°C - 35°C ≤ 75% RH)

AC Hi-Pot Specifications (H110 / H115 / H210 / H215)	
AC Voltage Range	100V to 5000V (5kV)
Voltage Step	5V/step
Voltage Regulation	1% of reading ± 5 counts
Voltage Accuracy	1% of reading ± 5 counts (above 500V)
Max Current	20mA @ 5kVAC
Current Limit	0.10 to 20mA, 0.01mA/step
Current Accuracy	1% of reading ± 5 counts
DC Hi-Pot Specifications (H210 / H215)	
DC Voltage Range	100V to 6000V (6kV)
Voltage Step	5V/step
Voltage Regulation	1% of reading ± 5 counts
Voltage Accuracy	1% of reading ± 5 counts (above 500V)
Max Current	7.5mA @ 6kVDC
Current Limit	0.10 to 7.5mA, 0.01mA/step
Current Accuracy	1% of reading ± 5 counts
Insulation Resistance Specifications (H115 / H215)	
DC Voltage	500V or 1000V
Resistance Range	1 to 9999MΩ
Resistance Accuracy	1 to 500MΩ: 5% of reading 501 to 2000MΩ: 10% of reading

Note: These instruments are not designed for continuous use at the maximum rating. The test procedure will automatically stop when temperature overload is detected.

Continuity Check Specifications:

Test Current: 100mA (0.1A)

Current Accuracy: $\pm 10\%$

Detect Accuracy: $0.1\Omega @ 1\Omega$

ARC Detect:

Detect Current: 1 to 20mA (1mA step)

Storage:

6 tests; 6 steps per test

Remote Interface:

Type of Terminal: 9-pin D-sub connector

Output Breakdown Voltage: $\pm 350V$

Continuous Load Current: $\pm 100mA$

General:

120VAC Power Source: 100V, 220V, 230V $\pm 10\%$ 50/60Hz
(selectable on the back panel)



Operation Environment:

Indoor use: altitude up to 2000m.

Ambient temperature: 32° to 104°F (0° to 40°C)

Relative humidity: 80% max.

Installation category II

Pollution degree 2

Storage Temperature & Humidity:

14° to 158°F (-10°C to 70°C), 70% RH max.

Dimensions: 17.56"(L) × 12.99"(W) × 5.87"(H)

446mm × 330mm × 149mm

Weight: Approx. 26.5 lbs.(12 kgs)

3. SAFETY PRECAUTIONS BEFORE OPERATION

3-1. Receiving your Shipment

Upon receiving your shipment, be sure that the contents are correct. Notify your distributor of any missing items. If the equipment appears to be damaged, file a claim immediately with the carrier and notify your distributor at once, giving a detailed description of any damage.

3-2. Contents

Each Hipot Tester is shipped with 1 high voltage probe, 1 return lead with retainer, a US AC 110V power cord, a user manual and product warranty registration card, and an extra fuse for 220V+ supply.

3-3. Safety Notice

Testing Environment - The working area must be isolated when high voltage testing is in progress. A warning sign, cautioning the presence of dangerous voltage should be clearly posted.

Checking the Line Voltage - The Hipot can be supplied by any of the line voltages shown in the table below. Before connecting the power plug to the AC outlet, make sure the voltage selector on the rear panel is set to the correct position corresponding to the line voltage of the AC outlet. Damage to the instrument could result if connected to the wrong AC line voltage.



WARNING. To avoid electrical shock, the power cord protective grounding conductor must be connected to ground.

When line supply voltages are changed, replace the fuses as shown below:

Line Voltage	Range	Fuse	Line Voltage	Range	Fuse
100V	90-110V	T 4.0A	220V	198-242V	T 2.0A
120V	108-132V	250V	230V	207-250V	250V



WARNING. To avoid personal injury, disconnect the power cord before removing the fuse holder.

 **Operator's Precaution**

- The Hipot tester supplies High Output Voltage and current. To avoid injuries and possible fatal electric shock, only qualified persons should operate the Hipot.
- On-the-job training is required for the user to operate the Hipot safely.
- Wearing metal jewelry when operating a Hipot is very dangerous. Remove all metal jewelry before operating the Hipot.
- Anyone who has a heart condition or a pacemaker must not operate the Hipot.

 **Secure Testing**

- Never operate the Hipot on live circuits.
- The instrument's ground/earth terminal (back panel) should be connected in accordance with instruction. The return lead must be connected to the sample under test before using the test probe.
- Do not plug the high voltage test probe into the high voltage output terminal while the tester is ON.
- Do not touch the metal tip on the test probe.
- The operator should be in full control of the power by using the ON/OFF switch or remote interface.

 **WARNING: During testing, do not touch the tested sample or any other object connected to the sample.**

3-4. Environment

The normal ambient temperature range of this Hipot is from 32° to 104°F (0° to 40°C). To operate the instrument outside this temperature range may result in damage to the Hipot.

Do not use the Hipot in places where strong magnetic or electric fields exist, as it may cause erroneous measurements.

4. OPERATION METHOD

4-1. Main Display

Storage	Mode	Output Voltage/Current	ARC	Status
1 : 1	V A C	V = 5 . 0 0 0 k V	*	M E N U
I m a x = 0 1 . 0 0 m A		T E S T 0 3 0 . 0 s		
Trip Current Limit		Ramp/Test Time		

(Actual settings may differ at power-up)

4-2. Table of Parameters

Storage	<p>Test: Step Up to 6 tests can be stored; each test may include up to 6 steps. The first number indicates the test number while the second number indicates the step. Ex. 3:1 means that the 1st Step in test number 3 is active.</p>
Mode	<p>The functions include: VAC: AC Withstanding voltage test VDC: DC Withstanding voltage test IR: Insulation Resistance test CNT: Continuity check The total available functions will change for different models.</p>

Output Voltage/ Current (for continuity)	<p>Output voltage or current for each step</p> <p>AC: Output voltage (0.100 to 5.000kV)</p> <p>DC: Output voltage (0.100 to 6.000kV)</p> <p>IR: Output voltage (500V or 1000V)</p> <p>CNT: Output current (100mA)</p>
Status	<p>The status includes:</p> <p>MENU: Browse and check the steps of each test</p> <p>EDIT: Edit parameters</p> <p>SAVE: Save parameters</p> <p>UTIL: Browse and check system utility</p> <p>READY: Ready for test</p> <p>TEST: Testing</p> <p>PASS: The result of the test is pass</p> <p>FAIL: The result of the test is fail</p> <p>STOP: Stop the test</p>
ARC	<p>If the ARC function is enabled, the sign “*” will appear when an ARC occurs during the test.</p>
Trip Current Limit	<p>Lower and upper limit of measurement</p> <p>I_{max}/I_{min}: Current measurement limit (VAC & VDC)</p> <p>R_{max}/R_{min}: Resistance measurement limit (IR & CNT)</p>
Ramp/Test Time	<p>Ramp time and test time</p> <p>AC: Ramp/Test (000.0 to 999.9s)</p> <p>DC: Ramp/Test (000.0 to 999.9s)</p> <p>IR: Test (000.0 to 999.9s)</p> <p>Cnt: Test (000.0 to 999.9s)</p> <div style="text-align: center;"> </div>

4-3. Preparing the Hipot Tester for Use

Viewing the Saved Steps:

1. Press the MENU key to enter the "MENU" mode.

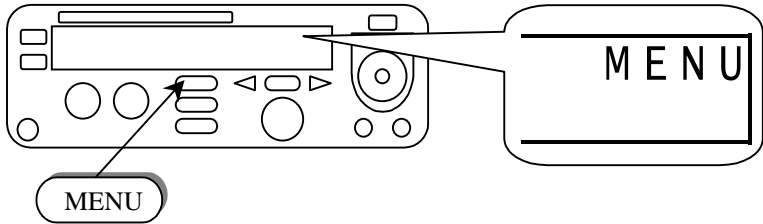

2. Use the rotary knob to select the test number.
(1:1, 2:1, 3:1 ... 0:0)

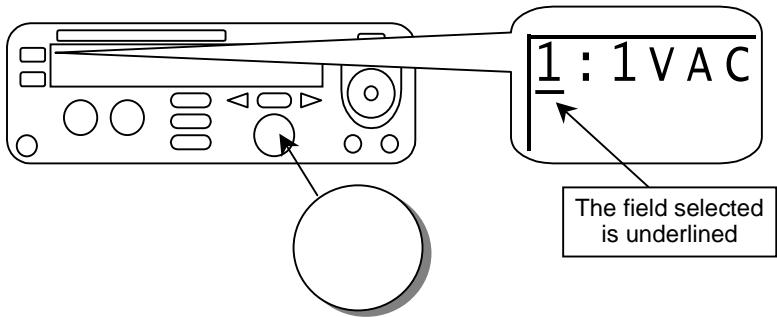

3. Use the right arrow key to select the step. Use the rotary knob to change the active step. (1:1, 1:2, 1:3 ... 1:6)

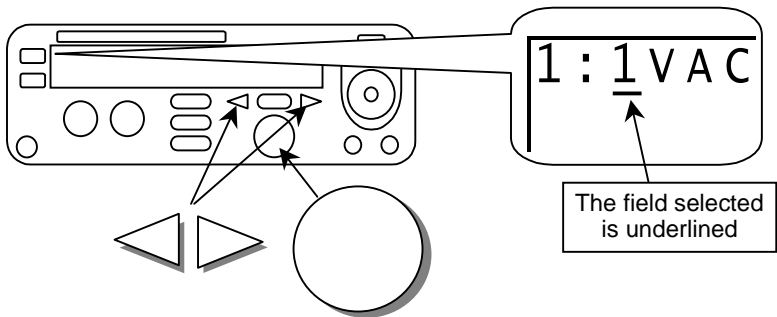

Edit/Save the Saved Steps:

1. Follow the preceding procedure for “**Viewing the Saved Steps**” to select a step.
2. Press the EDIT/SAVE key to enter status EDIT.

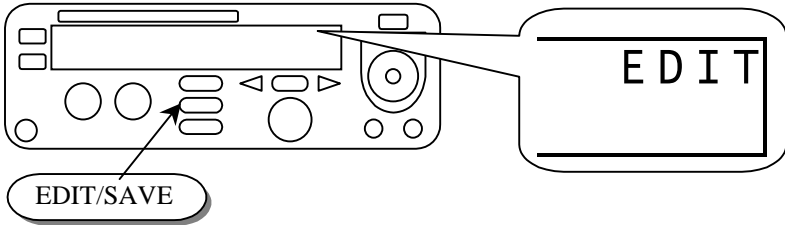

3. Use the rotary knob to adjust parameter.

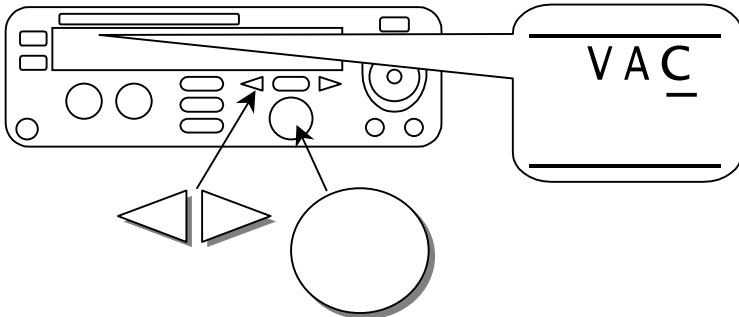

4. Use the FIELD key to change active parameter. Use the arrow keys to change the setting in the field. Adjust the underlined field with the rotary knob.

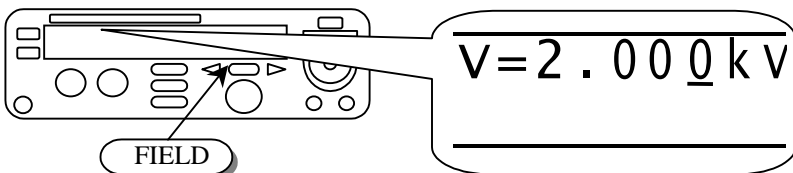

- Repeat steps 3 and 4 to adjust the parameter to the exact value (e.g. 3.250kV).
- After setting all parameters, press the EDIT/SAVE key to enter the "SAVE" mode. After the step is saved, the status will automatically return to the EDIT mode.

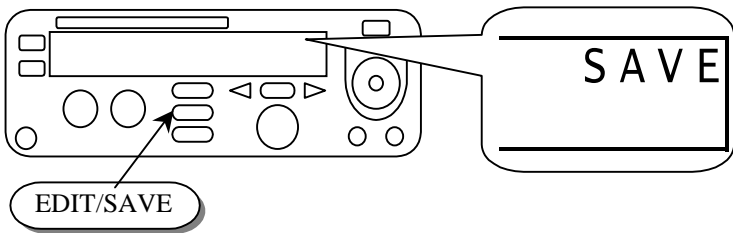

- Repeat the procedure for "**Viewing the Saved Steps**" to select another step.

Starting a Test:

1. Repeat the procedure for “**Viewing the Saved Steps**” to select a test (or step).
2. Press the STOP/RESET button to enter the “READY” mode.

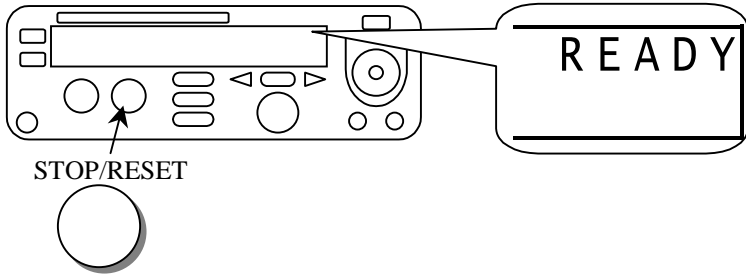

3. Make sure the test environment is safe.
4. Press the TEST button to start the test. When in the “TEST” mode, the CAUTION LED will flash.

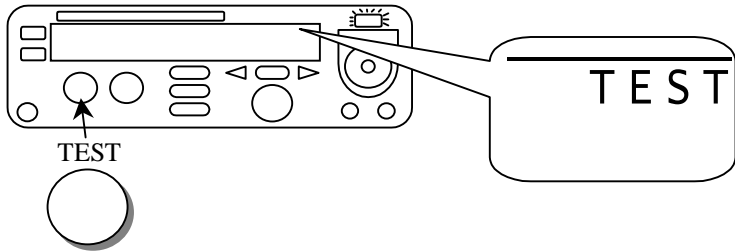

5. If you press the STOP/RESET button, the test will stop

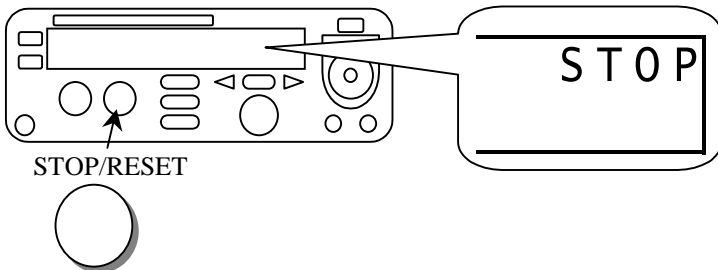

6. If the result of the test is good, the Green PASS LED will light.

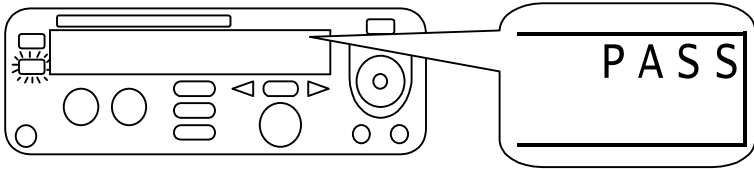

7. If the result of the test is bad, the Red FAIL LED will light and the buzzer will alert the operator. To stop the alarm, press the STOP/RESET button again.

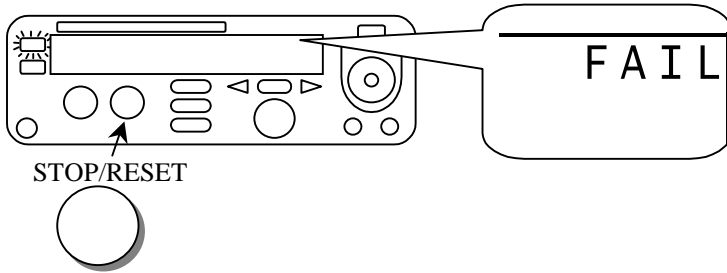

8. Use the rotary knob to view the result of the group step by step.

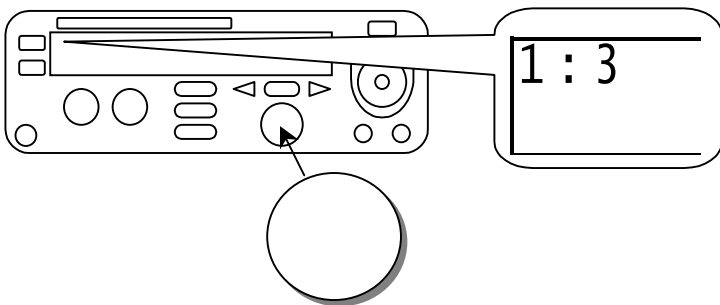

Viewing Utility Functions:

The utility function enables the user to program the start-up step in each test, as well as custom modes or features described in the table on the next page.

1. Press the UTILITY key to enter the "UTIL" mode.

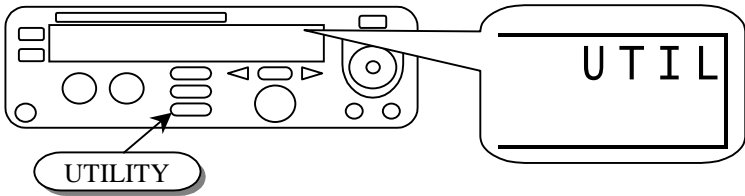

2. Use the rotary knob or arrow keys to change the active parameter.

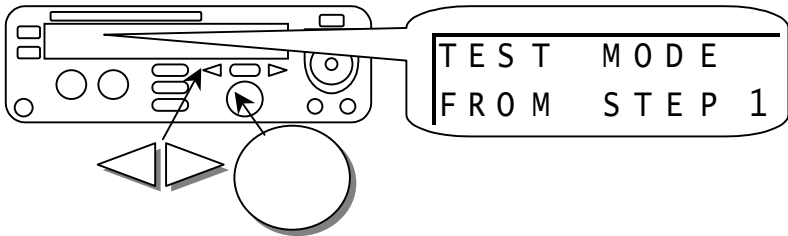

3. Table of utility functions:

To change the display option under a given mode, press EDIT and rotate the knob. Press SAVE to store the option.

Parameter	Option	Description
TEST MODE	From STEP 1	The test mode procedure always begins from step 1 to the end of the group. e.g. 3:1 - 3:6, 4:1 - 4:6
	From the present step	The test mode procedure always begins with the selected step to the end of the group. e.g. 3:3 - 3:6, 4:3 - 4:6
ARC MODE	DISABLE	Disables the ARC detection function.
	ENABLE & STOP	Enables ARC detection and stops the test when ARC is detected.
	ENABLE & CONTINUE	Enables ARC detection and continues the test when the arc is detected.
ARC CURRENT		Sets the current level of ARC detection. (1 to 20mA)
AC (TEST) FREQUENCY	50Hz	Sets AC Hipot output frequency to 50Hz.
	60Hz	Sets AC Hipot output frequency to 60Hz.
TEST CONTROL MODE	MODE 1	Control mode from the front panel. Mode 1: Reset first (recommended) (press RESET button before test)
	MODE 2	Mode 2: Press START button directly.
	MODE 3	Mode 3: REMOTE I/O is enabled. (the start button is disabled)
	MODE 4	Mode 4: Reserved.
DATA LOCK	UNLOCKED	Accepts and saves all parameters from the test/step and utility.
	LOCKED	Locks out any changes to parameters from the test/step and utility until unlocked.
CONT. CALIBRATION		Calibrates the short circuit resistance of test leads for test of continuity check.

Edit/Save Utility Functions:

1. Follow the above procedure for “**Viewing Utility Functions**” to select a parameter.
2. Press the EDIT/SAVE key to enter the “EDIT” mode.

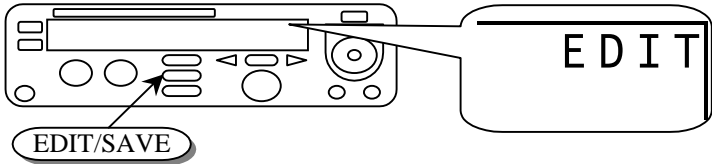

3. Use the rotary knob to adjust parameter.

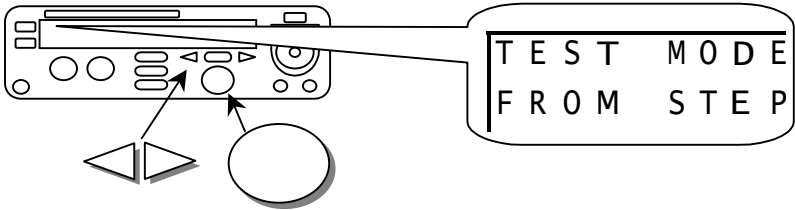

4. After setting this parameter, press the EDIT/SAVE key to enter the “SAVE” mode. After the parameter is saved, you will automatically return to the “EDIT” mode.

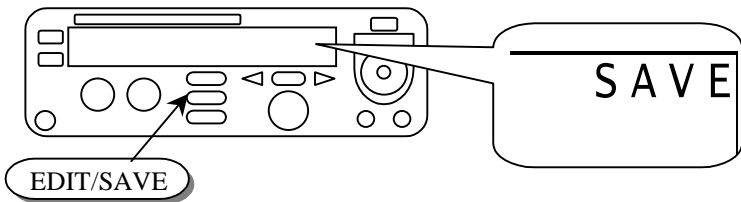

5. Repeat the procedure for “**Viewing Utility Functions**” to select another parameter.

4-4. Structure of Stored Tests : Steps

You can store a total of 6 tests with up to 6 steps per test. In addition to these six steps, there is an additional step, "0:0" for special testing. The presentation of stored steps is Test:Step. The first number represents the test, while the second represents the step as shown in the chart below.

		Test Group 1	Test Group 2	Test Group 3	Test Group 4	Test Group 5	Test Group 6
Step 1	0:0	1:1	2:1	3:1	4:1	5:1	6:1
Step 2		1:2	2:2	3:2	4:2	5:2	6:2
Step 3		1:3	2:3	3:3	4:3	5:3	6:3
Step 4		1:4	2:4	3:4	4:4	5:4	6:4
Step 5		1:5	2:5	3:5	4:5	5:5	6:5
Step 6		1:6	2:6	3:6	4:6	5:6	6:6

The special test step "0:0" contains two types of tests: CAC (continuous AC output) and CDC (continuous DC output). The function of CAC or CDC is the same as VAC or VDC, except that the user can manually adjust the output voltage during the tests (10V per step).

The ramp may be set, as well as the trip settings, however, the test will run until manually stopped or if a fault occurs.

4-5. Menu Parameter Setup

AC/DC Withstanding Voltage Test (VAC/VDC):

- Press the MENU key to enter the “MENU” mode, then use the rotary knob and arrow keys to select a step.
- Press the EDIT/SAVE key to enter the “EDIT” mode. The cursor enters the “**test mode**” field. Use the rotary knob to select mode VAC or VDC.

Functions of FIELD key:

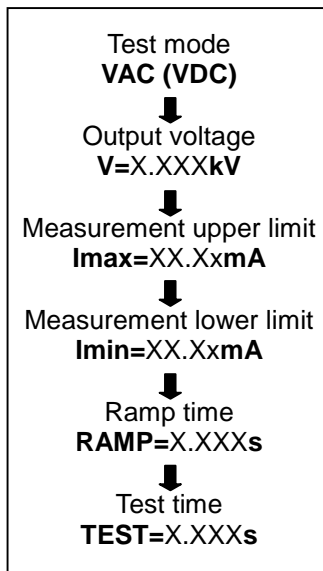

- Press the FIELD key to edit the next field which is “**output voltage**”. Use the rotary knob to adjust the desired output voltage. The arrow keys adjust the knob’s resolution (0.100 to 5.000kV for VAC, 0.100 to 6.000kV for VDC).
- Press the FIELD key again to enter the next field which is “**measurement upper limit**”. Use the rotary knob to adjust the desired upper limit of leakage current. The arrow keys adjust the knob’s resolution (0.10 to 20mA for VAC, 0.10 to 7.5mA for VDC).
- Press the FIELD key again to enter the next field which is “**measurement lower limit**”. Use the rotary knob to adjust the desired lower limit of leakage current. The arrow keys adjust the knob’s resolution (0.10 to 20mA for VAC, 0.10 to 7.5mA for VDC).
- Press the FIELD key again to enter the next field which is “**ramp time**”. Use the rotary knob to adjust the desired ramping time. The arrow keys adjust the knob’s resolution (0 to 999.9s).
- Press the FIELD key again to enter the next field which is “**test time**”. Use the rotary knob to adjust the desired testing time. The arrow keys adjust the knob’s resolution (0 to 999.9s).
- Press FIELD key again to return the first field which is “**test mode**” again.
- Press EDIT/SAVE key to save all the parameters.

Continuous AC/DC Withstanding Voltage Test (CAC/CDC)

- The CAC/CDC test is available only on the step “0:0”. Like the traditional hi-pot tester, you can use the rotary knob and arrow keys to adjust the output voltage during testing (10V step max.).
- All the parameters of CAC/CDC are the same as VAC/VDC, except the testing time. The testing of CAC/CDC is not limited (even if you program a time, the ramp is still adjustable).

Insulation Resistance Test (IR)

- Press the MENU key to enter the “MENU” mode, then use the rotary knob and arrow keys to select a step.
- Press the EDIT/SAVE key to enter the “EDIT” mode. The cursor enters the “**test mode**” field. Use the rotary knob to select the “IR” mode.

Functions of FIELD key:

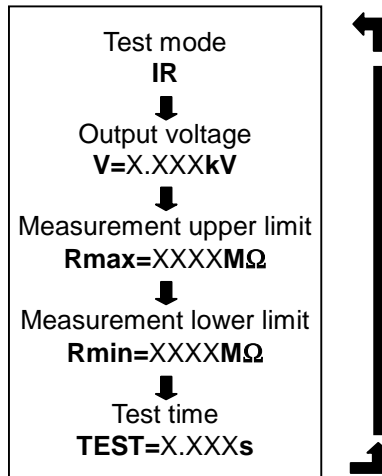

- Press the FIELD key to edit the next field which is “**output voltage**”. Use the rotary knob to adjust the desired output voltage to 500V or 1000V.
- Press the FIELD key again to enter the next field which is “**measurement upper limit**”. Use the rotary knob to adjust the desired upper limit of resistance. The arrow keys adjust the knob’s resolution (0 to 9999MΩ).
- Press the FIELD key again to enter the next field which is “**measurement lower limit**”. Use the rotary knob to adjust the desired lower limit of resistance. The arrow keys adjust the knob’s resolution (0 to 9999MΩ).
- Press the FIELD key again to enter the next field which is “**test time**”. Use the rotary knob to adjust the desired testing time. The arrow keys adjust the knob’s resolution (0 to 999.9s).

- Press the FIELD key again to return the first field which is “**test mode**”.
- Press the EDIT/SAVE key to save all the parameters.
- When Rmin=0 or Rmax=0 it only appears measurement value without making value limit judgment.

Continuity Check (CNT)

- Press the MENU key to enter the “MENU” mode, then use the rotary knob and arrow keys to select a step.
- Press the EDIT/SAVE key to enter the “EDIT” mode. The cursor enters the “**test mode**” field. Use the rotary knob to select mode CNT. The output current is fixed to 0.100A.

Functions of FIELD key:

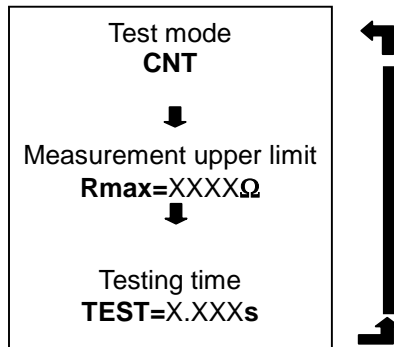

- Press the FIELD key to enter the next field which is “**measurement upper limit**”. Use the rotary knob to adjust the desired upper limit of resistance. The arrow keys adjust the knob’s resolution (0 to 1.200Ω).
- Press the FIELD key again to enter the next field which is “**test time**”. Use the rotary knob to adjust the desired testing time. The arrow keys adjust the knob’s resolution (0 to 999.9s).
- Press FIELD key again to return the first field which is “**test mode**”.
- Press the EDIT/SAVE key to save all the parameters.

Functions of the Remote Interface:

The remote interface provides two inputs (START and RESET) and three outputs (TESTING, PASS and FAIL).

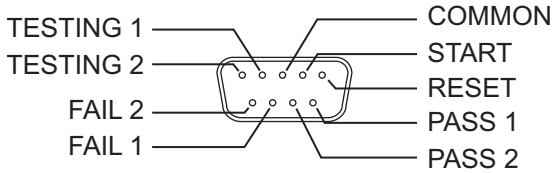

RESET: Connecting “RESET” (pin 1) to “COMMON” (pin 3) will reset the tester (provides the same functionality as the RESET button on the front panel).

START: In status READY mode, connecting “TESTING” (pin 2) to “COMMON” (pin 3) will start the test (provides the same functionality as the TEST button on the front panel).

TESTING 1,
TESTING 2: During test, the “TESTING 1” (pin 4) and TESTING 2” (pin 5) output pins will be shorted.

PASS 1,
PASS 2: If the test passed, the “PASS 1” (pin 6) and “PASS 2” (pin 7) output pins will be shorted.

FAIL 1,
FAIL 2: If the test failed, the “FAIL 1” (pin 8) and “FAIL 2” (pin 9) output pins will be shorted.

Hipot Electrical Safety Testers

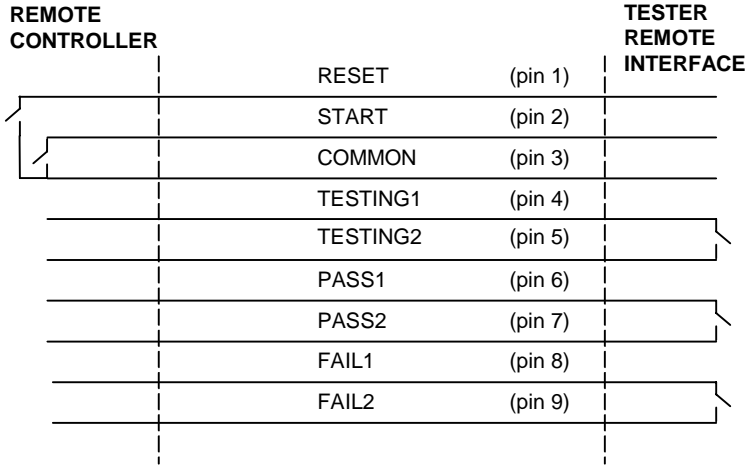

The function keys on the front panel are disabled when any two pins on the rear panel for Reset, Start or Common mode shorted.

Please check the remote control device.

5. MAINTENANCE

The following instructions are for qualified persons only.

To avoid electrical shock, do not perform any service other than the operating instructions contained in this manual, unless you are qualified to do so.



Use original replacement parts only.

5-1. Fuse Rating and Type

If the fuse blows, the product will not operate. Try to determine and correct the cause of the blown fuse, then replace the fuse with correct rating and type shown as below:

Line Voltage	Range	Fuse	Line Voltage	Range	Fuse
100V	90-110V	T 4.0A	220V	198-242V	T 2.0A
120V	108-132V	250V	230V	207-250V	250V



WARNING: Replace only with 250V fuse of the specified type and rating. Disconnect the power cord before replacing the fuse.

5-2. Cleaning

- To keep the instrument clean, wipe the case with a damp cloth and detergent.
- Do not use abrasives or solvents.
- Do not permit liquids or foreign matter to enter the Hipot.

Repair and Calibration

To ensure that your instrument meets factory specifications, we recommend that it be submitted to our factory Service Center at one-year intervals for recalibration, or as required by other standards or internal procedures.

For instrument repair and calibration:

You must contact our Service Center for a Customer Service Authorization number (CSA#). This will ensure that when your instrument arrives, it will be tracked and processed promptly. Please write the CSA number on the outside of the shipping container. If the instrument is returned for calibration, we need to know if you want a standard calibration, or a calibration traceable to N.I.S.T. (Includes Calibration Certificate plus recorded calibration data).

Chauvin Arnoux[®], Inc.
d.b.a. AEMC[®] Instruments
15 Faraday Drive
Dover, NH 03820 USA
Tel: (800) 945-2362 (Ext. 360)
(603) 749-6434 (Ext. 360)
Fax: (603) 742-2346 or (603) 749-6309

(Or contact your authorized distributor)

Costs for repair, standard calibration, and calibration traceable to N.I.S.T. are available.

Note: All customers must obtain a CSA# before returning any instrument.

Technical and Sales Assistance

If you are experiencing any technical problems, or require any assistance with the proper operation or application of your instrument, please call, mail, fax or e-mail our technical support hotline:

Chauvin Arnoux[®], Inc.
d.b.a. AEMC[®] Instruments
200 Foxborough Boulevard
Foxborough, MA 02035, USA
Phone: (800) 343-1391
(508) 698-2115
Fax: (508) 698-2118
www.aemc.com

Note: Do not ship Instruments to our Foxborough, MA address.



Chauvin Arnoux[®], Inc. d.b.a AEMC[®] Instruments
15 Faraday Drive • Dover, NH 03820, USA
www.aemc.com